

## Connections

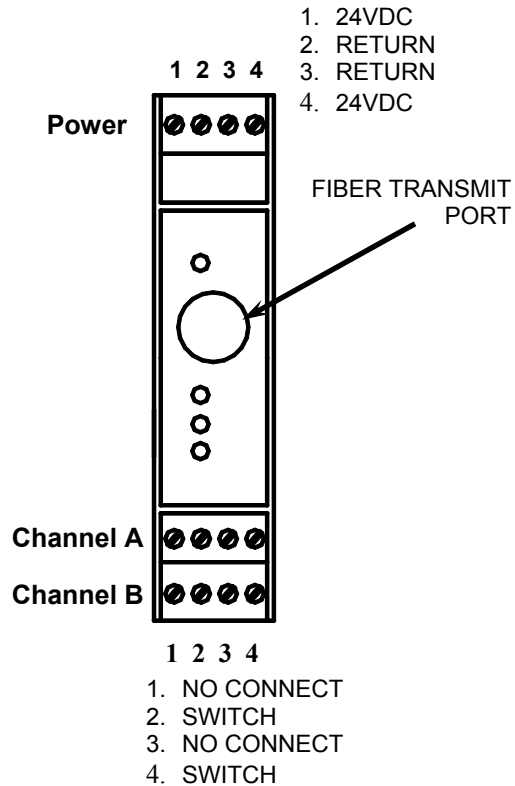

Note: Use shielded cable for all connections.

## Safety and Warning Information



Connect the DIN Rail via the End Clamp (2A09) to protective earth ground with low impedance. The modules are grounded to PE when they are snapped onto the DIN Rail.



When in operation, do not look directly into the transmit optical port or use magnification or focusing equipment to view optical output.

IEC 60825-1, Class 1 LED Product  
FDA 21 CFR 1040.10 & 1040.11

**CAUTION:** Use of controls and/or adjustments or the performance of procedures other than those specified herein may result in hazardous radiation exposure.

*Important Notice* - Before utilizing the product, the user should determine the suitability of the product for its intended use. The user assumes all risk and liability in connection with such use. WEED INSTRUMENT'S WRITTEN WARRANTY FOR THE PRODUCT IS MADE IN LIEU OF ALL OTHER WARRANTIES, EXPRESSED OR IMPLIED WARRANTIES OF MERCHANTABILITY AND FITNESS FOR A PARTICULAR PURPOSE. The user's exclusive remedy for breach of Weed Instrument's written warranty shall be the repair or replacement of such quantity of product which is proven to be defective. In no case shall Weed Instrument be liable for any special, incidental, or consequential damages based upon breach of contract, negligence, strict liability or other legal theory.

Weed Instrument Co., Inc.  
Round Rock, Texas, USA

[www.weedinstrument.com](http://www.weedinstrument.com)

Publication Number:

RM0900154 Rev. 3/04

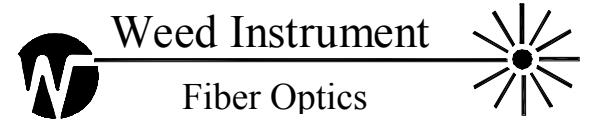

## 2S06

EOTec 2000 Multi-Channel  
Contact Closure  
Optical Transmit Module

## Installation Instructions



**Provides transfer of two channels of contact closure information over a single fiber to a partnered 2H06**

**For use with Multimode Glass Fiber, SMA Compatible Fiber Connections, 850nm Optical Wavelength**

Further technical information can be obtained by contacting Weed Instrument Co., Inc., Fiber Optic Products Group.

Phone: 1.800.880.9333  
512.434.2850

Fax: 512.434.2851

Email: [fiberop@weedinstrument.com](mailto:fiberop@weedinstrument.com)

Visit: [www.weedinstrument.com](http://www.weedinstrument.com)

## Operation

The 2S06 module provides for two independent channels of dry contact closure input signals which are multiplexed and conditioned for transmission over a single fiber optic output. The fiber optic signal transferred to the partnered 2H06 receiver module is then de-multiplexed and the actuation signals are transferred to their respective relay outputs. Closing a contact at an input causes a Form-C (SPDT) relay at the partnered output module to energize.

Up to four 2P02 (2-input) modules may be mated with the 2S06 transmit module and up to four 2K02 (2-output) modules may be mated with the 2H06 receiver module to increase the number of multiplexed contact closure channels to a total of ten. Communications between mated modules is achieved through the integrated BUS interconnections.

## Operational Settings

**Opening:** Use a small screwdriver to press on the latches (indentations) at the top and bottom of the housing. *Partially* slide the housing open.

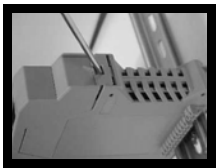

**Optical Power Setting:** The transmit optical power level default jumper position setting is "H" (High). Select position "L" (Low) *only* in overdriving (short fiber) conditions.

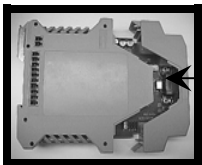

Optical Power Jumper

**Closing:** Close the housing by sliding it back together until both the top and bottom latches "click" into place.

## DIN Rail Mounting

### Installation on DIN rail:

Place the top lip of the module's DIN rail mounting channel onto the DIN rail. Push the lower portion of the module towards the mounting surface until it "clicks" and locks into place. Firmly slide the modules together such that the module sides are touching ensuring a good connection of the integrated BUS interconnection at the rear of the modules. Install End Clamps (Model 2A09) to both sides of the module bundle to prevent accidental unplugging of the BUS interconnections. The End Clamps also provide convenient screw terminals for connecting the DIN rail to Protective Earth (PE) ground.

### Removal from DIN rail:

Remove the End Clamps from the module bundle. Disconnect the BUS interconnections by sliding the modules at least 1/2" apart from each other on the DIN rail. Insert a screwdriver into the rectangular hole in the metal mounting latch at the bottom of the module. Pushing up on the screwdriver's handle causes the latch to move downward and disengages it from the DIN rail. Tilt the module up and lift it off of the DIN rail.

## Operating Power

A pluggable screw terminal block located at the top-front of the module accepts a nominal 24Vdc input and/or interconnect the unit with any EOTec 2000 power supply. In either case, operating power will be transferred via the integrated BUS interconnections to all adjacent modules.

## LED Indicators

### PWR (Power):

Green - On when operating power is present

### TX (Transmit Optical Activity):

Amber - On or flashing with activity

### CH A (Channel A):

Green - On when "A" input contacts are closed

### CH B (Channel B):

Green - On when "B" input contacts are closed

## Specifications

Mounting:	35mm DIN Rail
Weight:	< 9 oz (250g)
Power Requirements:	7.5 to 9.5Vdc @ 200mA, (supplied from any EOTec 2000 power supply) --or-- 12 to 30Vdc @ 700mA, via a pluggable, screw terminal block, located at the top-front of module, accepts 12 to 24 AWG
Data Update Rate:	15ms maximum, regardless of the number of channels utilized
Input Contacts:	External dry contacts (switches, relays, etc.) with a minimum 5Vdc @ 1.5mA rating and 1K $\Omega$ maximum contact/wiring resistance
Input Connection:	Via pluggable, screw terminal blocks, located at the bottom-front of module, accepts 12 to 24 AWG
Optical Wavelength:	850nm, LED
Optical Connections:	SMA Compatible
Fiber Compatibility:	200/230 $\mu$ m, Multi-mode
Optical Dynamic Range:	21dB
Operating Conditions	
Temperature:	-40 to 85°C
Relative Humidity:	0 to 95% (non-condensing)
Flammability:	UL 94V-0