

Model 753 Room Air Sensor

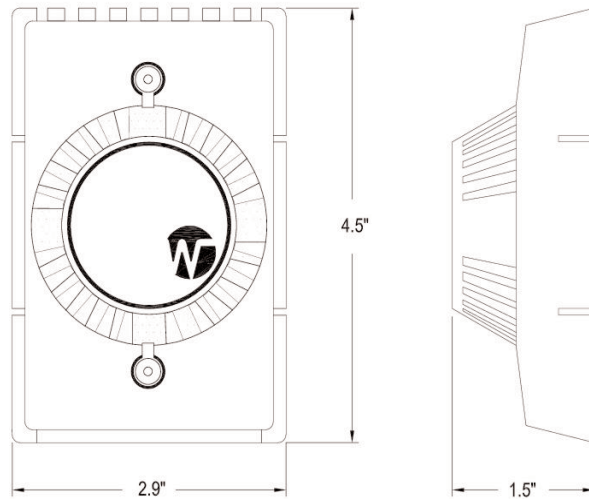

- Attractively styled wall mounted housing designed for even air flow around the sensor and optimal time response.
- Ideal for remote sensing when used in conjunction with the integral temperature transmitter.
- Unique housing design reduces the effects of self-heating created by the transmitter circuitry.



Specifications:

Element Type:	Code	PB	Pt RTD, 100 ohms @ 0°C (32°F), 0.00385055 TCR (DIN B)
		PC	Pt RTD, 1000 ohms @ 0°C, (32°F), 0.00385055 TCR (DIN B)
		TM	Thermistor, 10,000 ohms @ 25°C (77°F)
Max. Operating Temperature:	150°F		
Sensor Lead Wire:	RTD	Three 24 AWG Teflon insulated	
	Thermistor	Two 20 AWG polyolefin insulated	
Insulation Resistance:	Minimum 100 megohms @ 100 VDC @ (21°C) 70°F		
Stability:	RTD	Typically, 0.26C (0.47°F) over 5 years	
	Themistor	Typically, 1°C (1.8°F) over 5 years	
Accuracy:	RTD	± 0.3°C @ 0°C (± 0.56 °F @ 32°F)	
	Thermistor	± 0.2°C, from 0°C to 78°C (± 0.36 °F, from 32 °F to 158°F)	
	With Transmitter	Add 0.08% of span (RTD only)	
Transmitter Power Supply:	12-40 VDC		
Transmitter Output:	4 to 20 mA		
Load Resistance:	$R_{\max} = (V_{\text{supply}} - 12V) / 20\text{mA}$		

Code	Room Air Sensor
753-PB	RTD, 100 ohms @ 0°C (32°F) (DIN B)
753-PC	RTD, 1000 ohms @ 0°C (32°F) (DIN B)
753-TM	Thermistor, 10,000 ohms @ 25°C (77°F) - not available with transmitter Add code "MT" for match calibrated to transmitter. See RTD General Specifications.

For RTD assemblies with Integral Transmitter

Model	Integral Transmitter
X1	100 ohm platinum RTD input / 4-20mA output
X5	1000 ohm platinum RTD input / 4-20mA output
	Code Temperature Range
	(__ to __) Specify C° or F°

753 - PB	-	X1	-	(0° to 100°F)	← Sample Model Number (Sensor with Transmitter)
753 - PB	← Sample Model Number (Sensor without Transmitter)				
-	-	-	← Your Model Number		