

Model 305

Spring-Loaded RTD With 1/2" X 1/2" NPT Hex Nipple

Designed for applications where a spring-loaded threaded male fitting is required for mounting. It is intended to be used with a thermowell and to be compatible with any head that will accept a 1/2" NPT instrument thread. The spring-loading action of this RTD ensures proper contact with the tip of the thermowell for maximum heat transfer.



Model 305

- Refer to Model 301, 302, 303, & 304 if threaded fitting is not required.
- Refer to Model 201 if welded fitting is required.

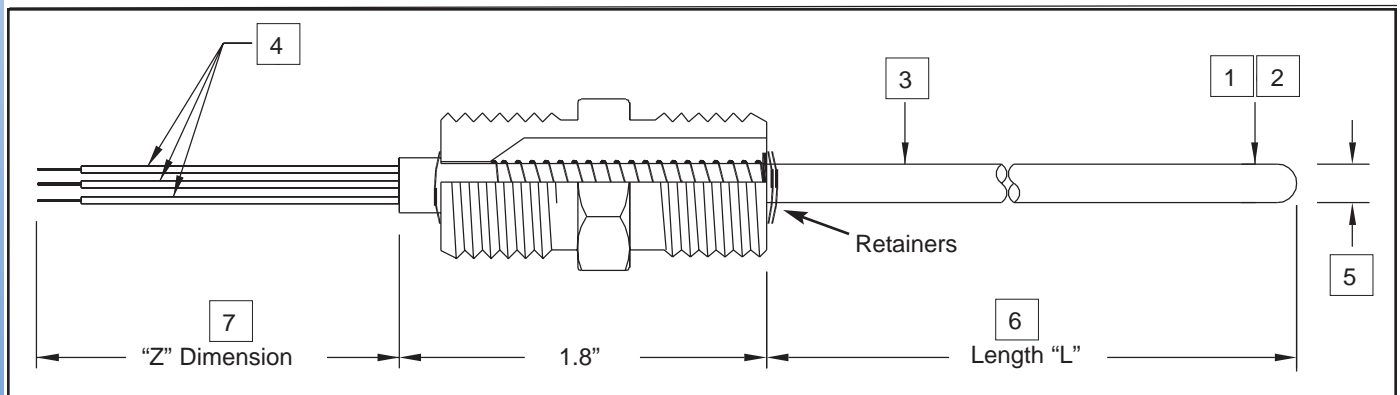

Specifications:

1. Base Model	Base Model/Series Number.	
2. A. Accuracy:	<i>Standard</i>	Class B (no code)
	<i>High</i>	Class A (code H)
	<i>Special</i>	Customer Specified (code S)
B. TCR:	* Industry Standard is DIN Curve (code 01B), Platinum, 100@ 0°C. Conforms to IEC 751.	
	Temperature Coefficient of Resistance is the temperature vs. resistance characteristics of a given metal (Pt, Cu & Ni) used in manufacturing the RTD. Determines the curve of the RTD.	
C. Ice Point Resistance:	R ₀ - Resistance at 0°C (32°F)	
3. Construction:	Code A - 316SS tube and wire construction, thin film element (.00385055) TCR, Teflon insulated lead wire. Code C - 316SS tube and wire construction, wire wound element, fiberglass insulated lead wire. Code B & D - Inconel sheathed MgO construction, wire wound element, fiberglass insulated lead wire.	
4. Lead Wires:		
5. Sheath Diameter:	.250" (1/4") is the industry standard.	
6. Sheath Length:	Bottom of fitting to tip of sensor. See sizing chart in RTD General Specifications.	
7. Lead Wire Length:	Length of wires beyond sheath.	
8. Water resistant:	Increases moisture protection for humid environments.	

Model	Description		
305	Spring-Loaded, 1/2" X 1/2" NPT Hex Nipple RTD (All Housings)		
1	Code	R ₀ & Temperature Coefficient	
	01B	100 ohm Platinum .00385055 TCR 100 ohms @ 0°C - Industry Standard	
	01A	100 ohm Platinum .003902 TCR 100 ohms @ 0°C	
	10A	1000 ohm Platinum .003902 TCR 1000 ohms @ 0°C	
	10B	1000 ohm Platinum .00385055 TCR 1000 ohms @ 0°C	
	12N	120 ohm Nickel .00672 TCR 120 ohms @ 0°C	
	09C	10 ohm Copper (9.035) .004274 TCR 10 ohms @ 25°C	
	Add Code "H" for higher accuracy Add Code "S" for special accuracy Add Code "M_", ME for matched to element, MT for matched to transmitter, MP for two matched probes.		
	2	Code	Construction Temperature Limit
		A	500° F Maximum
C		900° F Maximum (Platinum Only)	
D		1200° F Maximum (Platinum Only)	
3	Code	Number of Lead Wires	
	2	2-Wire (No lead Compensation)	
	3	3-Wire (Lead Compensation)	
	4	4-Wire (Complete Compensation)	
	6	Dual 3-Wire (With dual element)	
4	Code	Sheath Diameter	
	C	.250" (1/4") Diameter	
5	Code	Sheath Length	
	XXX.X	Specify length to nearest 0.1"	
6	Code	Lead Wire Length	
	Z06	6" - Standard with head	
	Z024	24" - Standard without head	
7	Code	Option	
	W	Water Resistant	
8			

305	-	01B	-	A	-	3	-	C	-	012.0	-	Z006	-
-	-	-	-	-	-	-	-	-	-	-	-	-	-

Sample Model Number

Your Model Number