

Model 305

Spring Loaded, 1/2" x 1/2" NPT Hex Nipple Thermocouple

Designed for applications where a spring-loaded threaded male fitting is required for mounting. The spring loading action ensures proper contact with the tip of the thermowell for maximum heat transfer. The sensor is intended to be used with a thermowell, not intended for direct immersion applications.

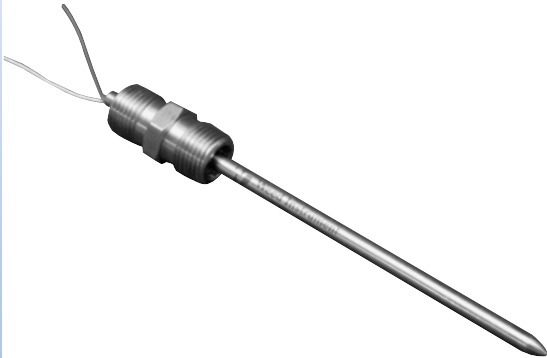

- Refer to 300 Series if threaded fitting is not required.
- Refer to Model 201 if welded fitting is required.

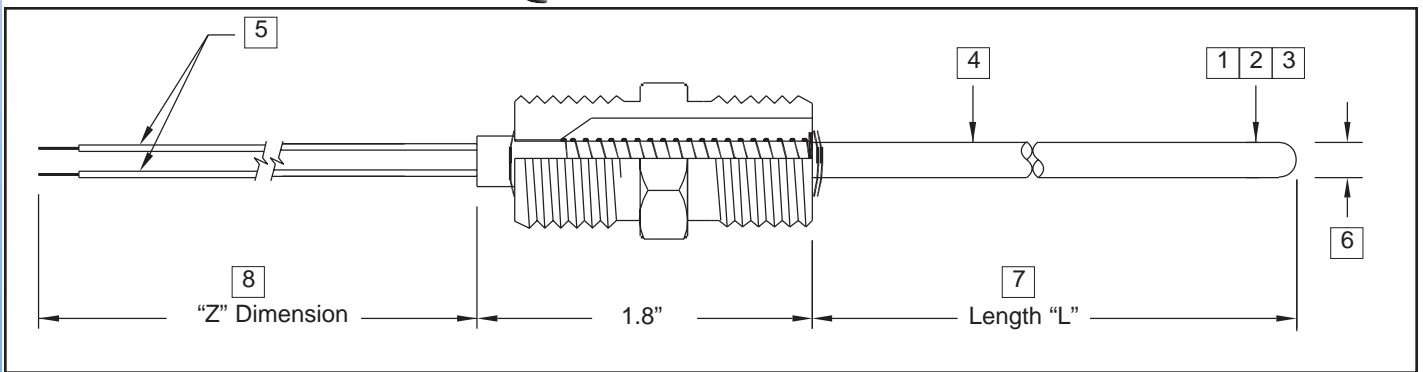

Specifications:

1. Base Model	Base Model/Series Number.
2. A. Accuracy:	ANSI Special Limits of Error is standard. See Thermocouple General Specifications.
B. Type:	Application dependent. See Thermocouple General Specifications.
C. Response Time:	Dependent on sheath diameter and measuring junction. See Thermocouple General Specifications.
D. Tip Sensitivity:	Thermocouples are inherently tip sensitive.
3. Grounded:	At the tip, thermocouple wires are attached to inside of probe wall, resulting in quick response time.
Ungrounded:	At the tip, thermocouple wires are insulated from the inside of probe wall, results are a slower response time but increased isolation.
4. Construction:	Code A - 316SS tube construction, teflon insulated lead wire. Code C - 316SS MgO construction, fiberglass insulated lead wire. Code B - Inconel sheathed MgO construction, fiberglass insulated lead wire.
5. Lead Wires:	<div style="display: flex; justify-content: space-around; align-items: center;"> <div style="text-align: center;"> <p>Single</p> </div> <div style="text-align: center;"> <p>Dual</p> </div> </div>
6. Sheath Diameter:	.250" (1/4") is industry standard.
7. Sheath Length:	Bottom of fitting to tip of sensor.
8. Lead Wire Length:	Length of wires beyond the sheath.

Model	Description		
305	Spring-Loaded, 1/2" X 1/2" NPT Hex Nipple Thermocouple (All Housings)		
1	Code	Thermocouple Type	Range
	J	Type J Thermocouple	32 to 1400°F 0 to 760°C
	K	Type K Thermocouple	-328 to 2300°F -200 to 1260°C
	T	Type T Thermocouple	-328 to 700°F -200 to 371°C
	E	Type E Thermocouple	-328 to 1600°F -200 to 871°C
	R	Type R Thermocouple	32 to 2700°F 0 to 1482°C
	S	Type S Thermocouple	32 to 2700°F 0 to 1482°C
	B	Type B Thermocouple	32 to 3100°F 0 to 1704°C
	N	Type N Thermocouple	-454 to 2372°F -270 to 1300°C
	Add "MT" for matched to transmitter. See Thermocouple General Specifications.		
2	Code	Junction Type	
	G	Grounded	
3	Code	Temperature Range	
		A 500° F Maximum	
		C 1600° F Maximum	
4	Code	Number of Lead Wires	
		2 Single Thermocouple	
5	Code	Sheath Diameter	
		C .250" Diameter	
6	Code	Sheath Length	
		XXX.X Specify length to nearest 0.1"	
7	Code	Lead Wire Length	
		Z003 3" - Standard with head	
		Z024 24" - Standard without head	
8	Code	Other - consult factory	

305	-	J	-	G	-	C	-	2	-	C	-	012.0	-	Z003
-	-	-	-	-	-	-	-	-	-	-	-	-	-	-

Sample Model Number
Your Model Number

